

鎢鋼銑牙刀-部份成型60°(內牙/外牙) Carbide Thread Milling Tools-Partial Profile 60° (Internal / External)

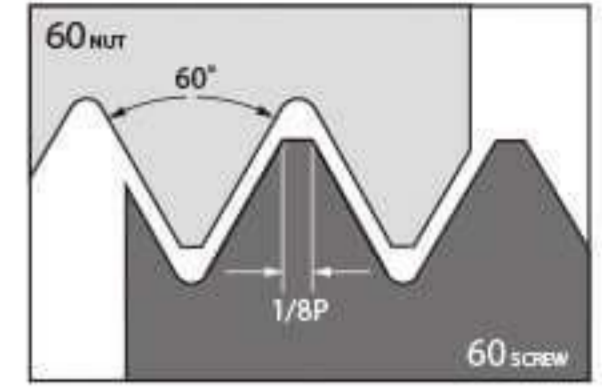

編號 (Number)	間距 (Pitch Range)		外徑 (D)	有效長 (H)	刃數 (T)	頭徑 (N)	柄徑 (d)	全長 (L)	價格 (Price)
	MM	TPI							
JF60T0195	0.35-0.6	72-40	1.95	6	3	0.75	3	50	
JF60T0245	0.5-0.8	48-32	2.45	7.7	3	0.95	3	50	
JF60T0315	0.5-0.8	48-32	3.15	10	3	1.65	4	50	
JF60T0400	0.5-1.0	48-24	4	12	3	2.07	4	50	
JF60T0470	0.5-1.25	48-20	4.7	15	3	2.33	6	60	
JF60T0600	0.5-1.25	48-20	6	18	3	3.63	6	60	
JF60T0800	0.75-1.5	32-16	8	24	3	5.15	8	60	
JF60T1000	1.0-2.5	24-10	10	30	4	5.28	10	80	
JF60T1200	1.0-2.5	24-10	12	36	4	7.28	12	80	
JF60T1600	1.0-2.5	24-10	16	49	4	11.28	16	100	

鎢鋼銑牙刀-部份成型55°(內牙/外牙) Carbide Thread Milling Tools-Partial Profile 55° (Internal / External)

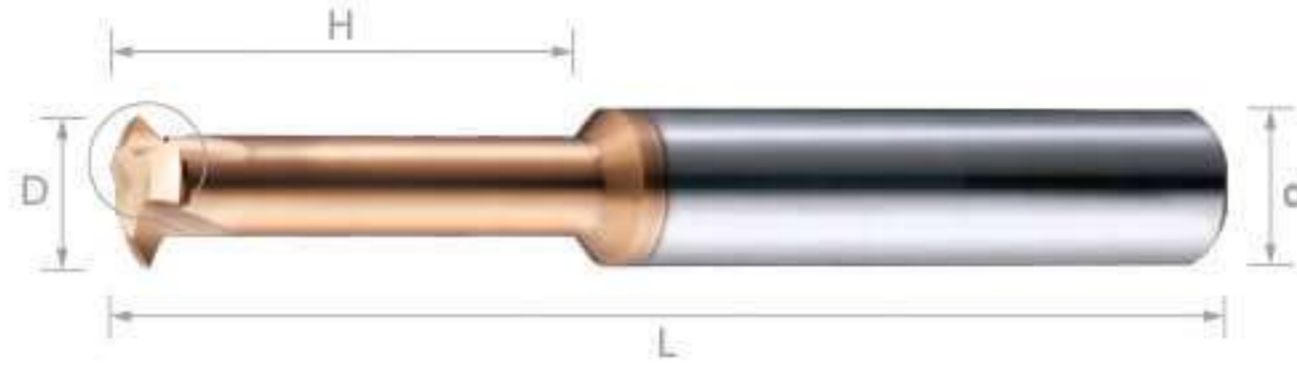
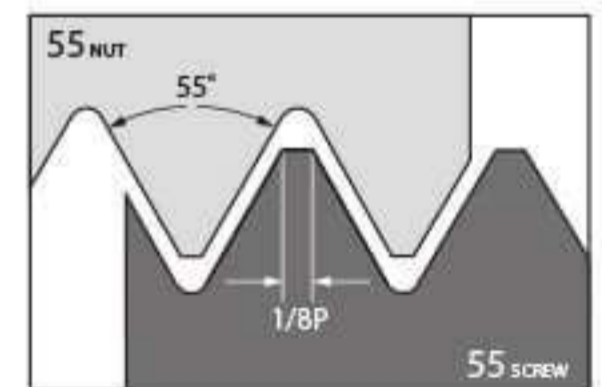
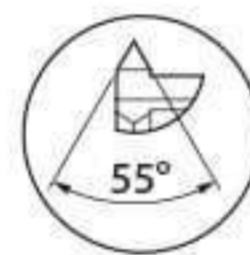
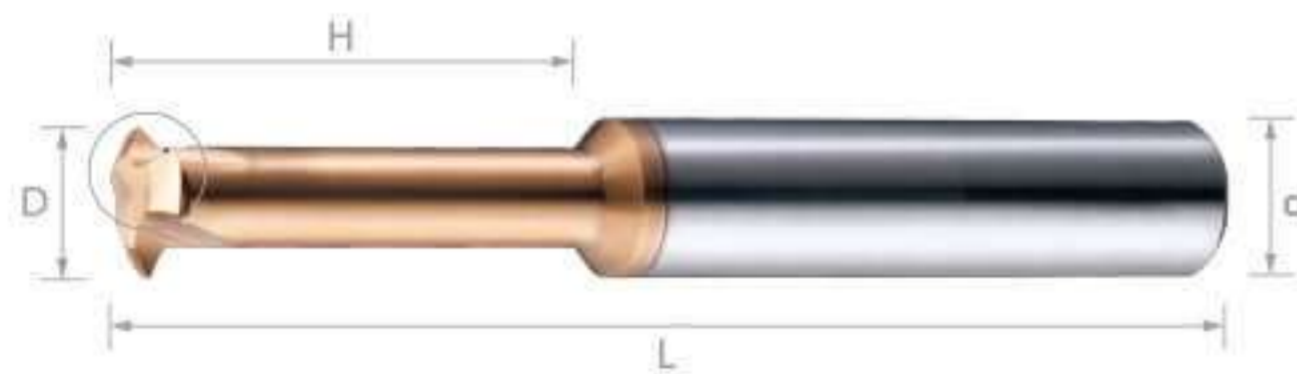

編號 (Number)	間距 (Pitch Range)		外徑 (D)	有效長 (H)	刃數 (T)	頭徑 (N)	柄徑 (d)	全長 (L)	價格 (Price)
	MM	TPI							
JF55T0400	0.5-1.0	48-24	4	12	3	2.1	4	50	
JF55T0600	0.5-1.25	48-20	6	18	3	3.95	6	60	
JF55T0800	0.75-1.5	32-16	8	24	3	3.85	8	60	
JF55T1000	1.0-2.5	24-10	10	30	4	4.5	10	80	
JF55T1200	1.0-2.5	24-10	12	36	4	5.4	12	80	