

鎢鋼全球頭球型銑刀 (標準型/長柄型) 260°

Carbide 260° Ball Nose End Mills (Standard / Long Shank) 260°

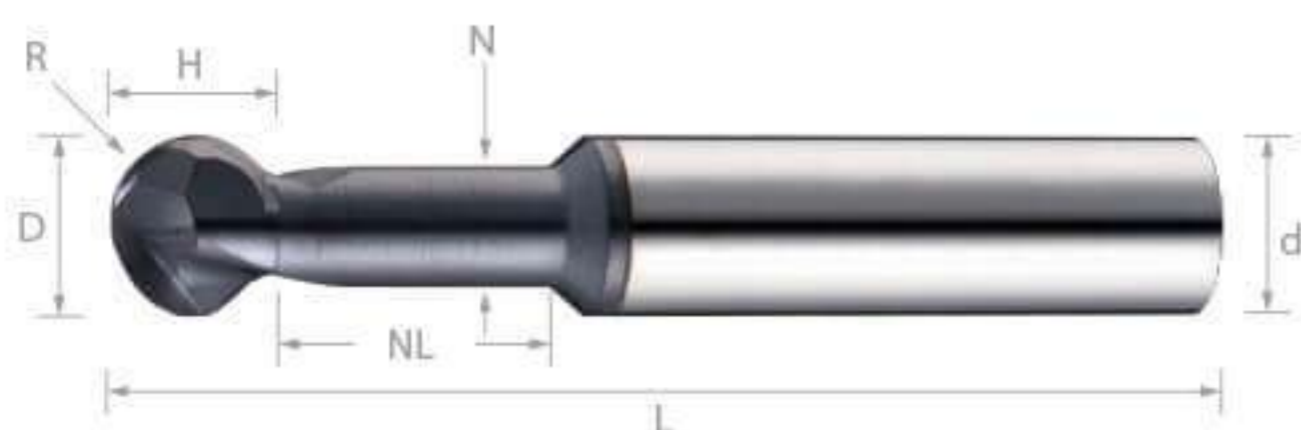

編號 (Number)	球半徑 (R)	外徑 (D)	刀長 (H)	頸徑 (N)	頸長 (NL)	刀數 (T)	柄徑 (d)	全長 (L)	價格 (Price)
JEB0204	1R	2	1.63	1.53	3	2	4	50	
JEB0304	1.5R	3	2.46	2.3	3	2	4	50	
JEB0404	2R	4	3.3	3.06	5	2	4	50	
JEB0506	2.5R	5	4.1	3.83	5	2	6	50	
JEB0606	3R	6	4.93	4.6	5	2	6	50	
JEB0808	4R	8	6.58	6.15	6	2	8	60	
JEB1010	5R	10	8.22	7.66	8	2	10	75	
JEB1212	6R	12	9.86	9.2	10	2	12	75	
JEB1616	8R	16	13.37	12.26	10	2	16	100	

編號 (Number)	球半徑 (R)	外徑 (D)	刀長 (H)	頸徑 (N)	頸長 (NL)	刀數 (T)	柄徑 (d)	全長 (L)	價格 (Price)
JEBL0204	1R	2	1.63	1.53	3	2	4	75	
JEBL0304	1.5R	3	2.46	2.3	3	2	4	75	
JEBL0404	2R	4	3.3	3.06	5	2	4	75	
JEBL0506	2.5R	5	4.1	3.83	5	2	6	75	
JEBL0606	3R	6	4.93	4.6	5	2	6	75	
JEBL0808	4R	8	6.58	6.15	6	2	8	100	
JEBL1010	5R	10	8.22	7.66	8	2	10	100	
JEBL1212	6R	12	9.86	9.2	10	2	12	100	