

SEP 鎢鋼鋁用銑刀 (加長型/圓溝型/4倍長) 50°-3刃

SEP Carbide Aluminum End Mills (Long Flutes / U-Flute Shape / 4xH) 50° - 3 Flutes

JC
鋁用系列

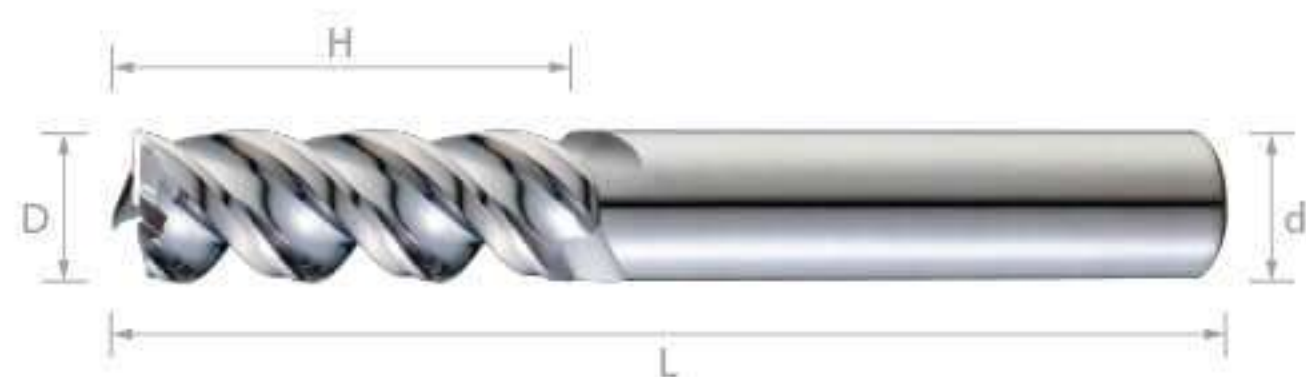

編號 (Number)	外徑 (D)	刃長 (H)	刃數 (T)	柄徑 (d)	全長 (L)	價格 (Price)
JCUL0304	3	12	3	4	50	
JCUL0404	4	16	3	4	50	
JCUL0306	3	12	3	6	50	
JCUL0406	4	16	3	6	50	
JCUL0506	5	20	3	6	50	
JCUL0606	6	24	3	6	60	
JCUL0808	8	32	3	8	75	
JCUL1010	10	40	3	10	100	
JCUL1212	12	50	3	12	100	
JCUL1616	16	65	3	16	150	
JCUL2020	20	80	3	20	150	

SEP 鎢鋼鋁用銑刀 (加長型/圓溝型/5倍長) 50°-3刃

SEP Carbide Aluminum End Mills (Long Flutes / U-Flute Shape / 5xH) 50° - 3 Flutes



編號 (Number)	外徑 (D)	刃長 (H)	刃數 (T)	柄徑 (d)	全長 (L)	價格 (Price)
JCUS0204	2	10	3	4	50	
JCUS0304	3	15	3	4	60	
JCUS0404	4	20	3	4	60	
JCUS0306	3	15	3	6	60	
JCUS0406	4	20	3	6	60	
JCUS0506	5	25	3	6	75	
JCUS0606	6	30	3	6	75	
JCUS0808	8	40	3	8	100	
JCUS1010	10	50	3	10	100	
JCUS1212	12	55	3	12	100	
JCUS1616	16	75	3	16	150	
JCUS2020	20	100	3	20	150	

JLC