

# 極細微粒鎢鋼粗銑刀 (標準型) -4刃

Ultra Fine Carbide Rough Cutting End Mills ( Standard ) - 4 Flutes

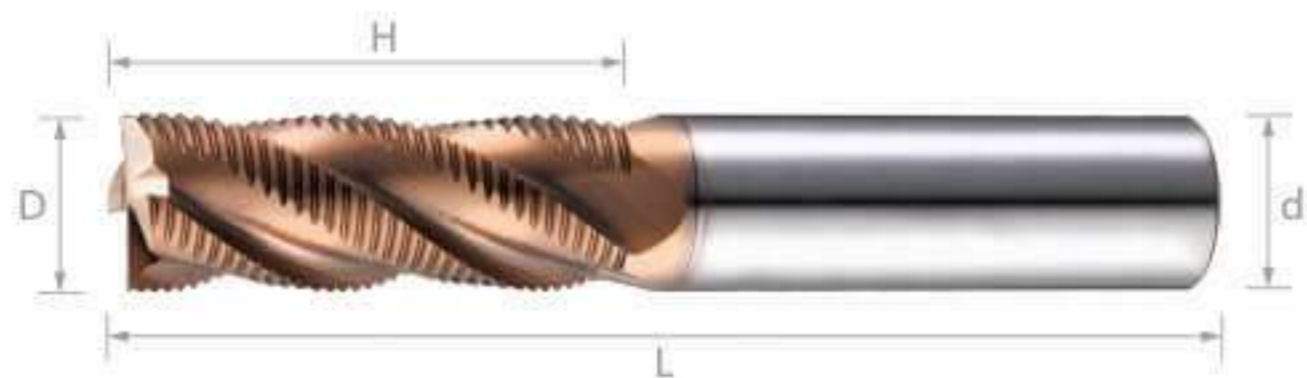

編號 (Number)	外徑 (D)	刃長 (H)	刃數 (T)	柄徑 (d)	全長 (L)	價格 (Price)
JAR0606	6	15	4	6	50	
JAR0808	8	20	4	8	60	
JAR1010	10	30	4	10	75	
JAR1212	12	32	4	12	75	
JAR1616	16	45	4	16	100	
JAR2020	20	50	4	20	100	

# 極細微粒鎢鋼粗銑刀 (不等分割變導型) -4刃

Ultra Fine Carbide Rough Cutting End Mills ( Variable Lead ) - 4 Flutes

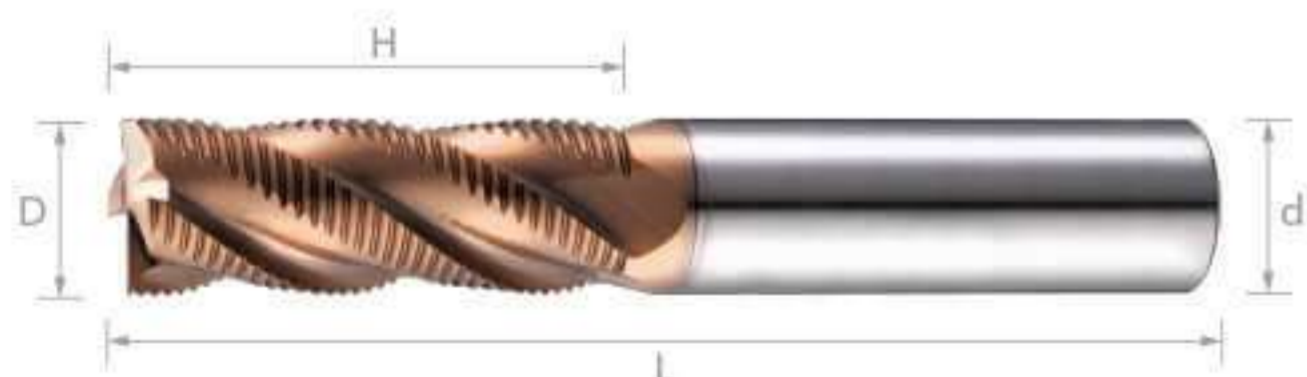

編號 (Number)	外徑 (D)	刃長 (H)	刃數 (T)	柄徑 (d)	全長 (L)	價格 (Price)
JARV0606	6	15	4	6	50	
JARV0808	8	20	4	8	60	
JARV1010	10	30	4	10	75	
JARV1212	12	32	4	12	75	
JARV1616	16	45	4	16	100	
JARV2020	20	50	4	20	100	

